

Disclaimers

1. Use of Technical Information

The technical information published on this website is intended and made available only to users who have the necessary professional and technical skills, knowledge and qualifications, as well as the necessary equipment and tools. Specific repair or maintenance operations must be performed with the appropriate specified equipment and tools, and replacement parts or components. Any repair or maintenance operation undertaken by any user of this website on the basis of, as a result of or in connection with the technical information published on this website is performed under the sole responsibility of such user, and Toyota Motor Europe NV/SA, any of its affiliated companies and/or any of its national distributors cannot be held liable for any bodily injury, damage to property, loss, expenses or any other damage, or any infringement to any laws or regulations, as a result of any such repair or maintenance operation.

2. Warranty information contained within these documents

Any information which specifically relates to the terms and conditions of any specific warranty action undertaken by Toyota Motor Europe NV/SA, any of its affiliated companies and/or any of its national distributors, and which is included in any document published on this website, does not constitute technical information. Such information relates to past warranty actions undertaken by Toyota Motor Europe NV/SA, any of its affiliated companies and/or any of its national distributors, and, as a consequence, neither Toyota Motor Europe NV/SA nor any of its affiliated companies or any of its national distributors are bound by such warranty actions, or any term and condition thereof. Under no circumstances shall such information constitute any undertaking, commitment or promise by Toyota Motor Europe NV/SA, any of its affiliated companies and/or any of its national distributors to apply, extend or renew such warranty action.

3. Upgrade or repair entitlement

The fact that a piece of technical information which relates to a specific upgrade or repair work for any specific range of vehicles has been published on this website, and that the vehicle belonging or used by a user of this website falls within such range, does not, as such, mean that the user's vehicle effectively needs to be upgraded or repaired or that they would be entitled to such upgrade or repair, whether against payment or under any warranty action.

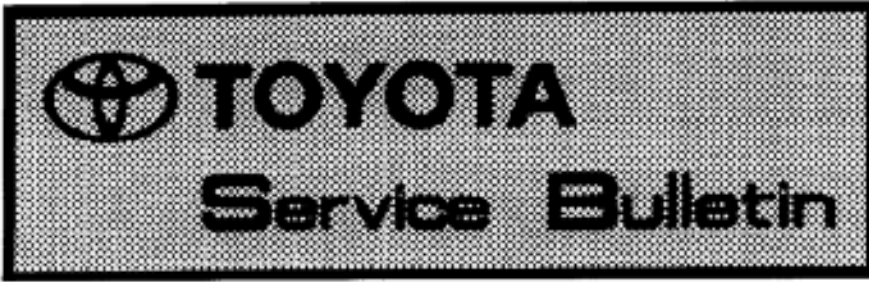

Section : Wind Noise
 Squeak / Rattle
 Ref. No. : WS-1001
 Date : August 2001
 Page : 1 of 2

Area Application: USA/Canada, Europe, Australia, Others (Hong Kong, Singapore)

Model Name: PRIUS

Model Code: NHW11

Subject: SQUEAK NOISE FROM FRONT SEAT TRACK

This Service Bulletin is to inform you of the Production Countermeasure and the Field Fix Method for the subject noise which can be heard during driving on rough road and/or cornering.

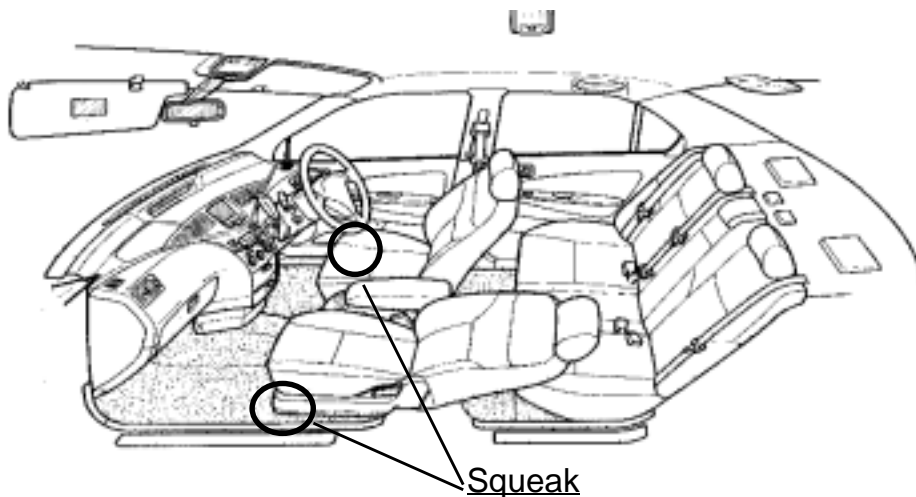

Production Countermeasure

Material of protectors which are installed between front seat tracks (outside only) and front cross member as shown below has been changed from felt to film tape to prevent the squeak noise.

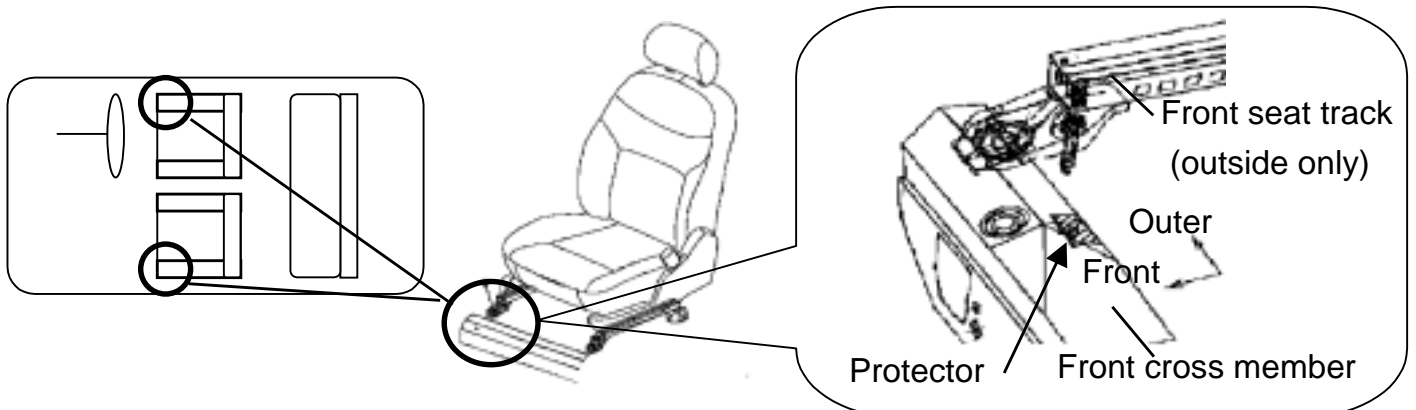

Service Bulletin

Ref. No. : WS-1001

Page : 2 of 2

Production Effective:

Production Date	Frame No. (Reference only)
August 22, 2001	0039717

Part No. Information:

Prev. Part No.	New Part No.	Part Name	Qty
72129-47010	72129-47020	Protector, Seat Track Lower Rail	2

Field Fix Method

Remove the original protector (felt) and stick a new protector (film tape) on the front cross member as shown below (outside seat tracks only).

